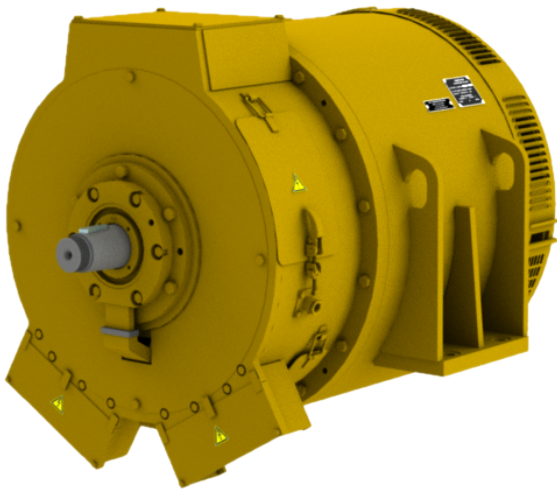

**TRACTION SYNCHRONOUS ALTERNATOR GSN-700/8**
GPIN.528254.002 TU (Technical condition)

The alternator is intended to be used for feeding electric motors of BelAZ dump trucks with a weight capacity up to 90 t.

Types of climatic version – NF2 acc. to GOST 15150-69.

Operation category according to the affection by the mechanical factors of the outdoor environment M28 acc. to GOST 30631-99.

Heat resistance of the insulating materials as for the alternator stator windings corresponds to "H" class, for rotor winding – "F" class, for contact rings – "B" class acc. to GOST 8865-93.

The direction of rotation of the alternator – left (from contact rings).

Excitement of the alternator – from an auxiliary winding from the stator slots (excitement from the third harmonica of the field in an air gap).

Category of the alternator relating to assembly type – M9809 acc. to GOST 2479-79, with the flange end of a shaft on D-end

and taper lock end of a shaft on N-end.

Alternator IP category – IPW 21 acc. to GOST IEC 60034-5-2011 in case of joint operation with diesel plant.

Alternator cooling system – IC11 acc. to GOST R MEK 60034-6-2012.

The alternator can be operated at the heights of up to 1200 m above sea level.

Basic technical specifications

Parameter	Value
Rated capacity, kW	700
Nominal voltage (line voltage), V	
– min	510*
– max	800*
Current, A	
– min	546
– max	870
Rotating speed, sec^{-1} (rpm)	30 (1800) / 31.67 (1900)**
Current frequency, Hz	120 / 126.67**
Excitation current, A	240 / 230***
Efficiency, %, above	94.8 / 94.6
Duty type acc. to GOST IEC 60034-1-2014	S1 (continuous)
Weight, kg, max	2500

Remarks:

*Voltage on rectifier conclusions on a direct current: min – 610 V, max – 1000 V.

**Depending on the rotating speed of the diesel engine.

***The excitement current corresponding to a point of the duty type S1 – max.

The alternator shall be admitted for operation with wattage increase up to 850 kW in duty type S6 60%.

The alternator without damages and residual deformations maintains within 2 min emergency increase in frequency of rotation to 38 sec^{-1} (2280 rpm).



MAIN OVERALL AND INSTALLATION DIMENSIONS OF THE ALTERNATOR GSN-700/8

